

M

MAINTAINING SENIORS'
INDEPENDENCE THROUGH
HOME ADAPTATIONS



**A Self-Assessment
Guide**



HOME TO CANADIANS
Canada

CMHC—HOME TO CANADIANS

Canada Mortgage and Housing Corporation (CMHC) is the Government of Canada's national housing agency. We help Canadians gain access to a wide choice of quality, affordable homes.

Our mortgage loan insurance program has helped many Canadians realize their dream of owning a home. We provide financial assistance to help Canadians most in need to gain access to safe, affordable housing. Through our research, we encourage innovation in housing design and technology, community planning, housing choice and finance. We also work in partnership with industry and other Team Canada members to sell Canadian products and expertise in foreign markets, thereby creating jobs for Canadians here at home.

We offer a wide variety of information products to consumers and the housing industry to help them make informed purchasing and business decisions. With Canada's most comprehensive selection of information about housing and homes, we are Canada's largest publisher of housing information.

In everything that we do, we are helping to improve the quality of life for Canadians in communities across this country. We are helping Canadians live in safe, secure homes. CMHC is home to Canadians.

Canadians can easily access our information through retail outlets and CMHC's regional offices.

You can also reach us by phone at 1 800 668-2642
(outside Canada call (613) 748-2003)
By fax at 1 800 245-9274
(outside Canada (613) 748-2016)

To reach us online, visit our home page at www.cmhc.ca

Printed: 2003
Revised: 2003

Canada Mortgage and Housing Corporation supports the Government of Canada policy on access to information for people with disabilities. If you wish to obtain this publication in alternative formats, call 1 800 668-2642.

Maintaining Seniors' Independence Through Home Adaptations

A Self-Assessment Guide

Cette publication est aussi disponible en français sous le titre :
*Maintenir l'autonomie des aînés par l'adaptation des logements:
Guide d'évaluation par les aînés (61276)*

Introduction

The overwhelming majority of seniors wish to continue to live in their own homes for as long as possible. However, many homes are not well designed to meet our changing needs as we age.

This publication identifies the types of difficulties that seniors can experience and describes types of adaptations that can help overcome these difficulties.

Using the Guide

Each of the sections of this guide, listed in the Table of Contents, deals with an activity in the home. In using each section of the guide, first decide whether you are having difficulty with the described activity. If you are, examine the types of adaptations described in the section and decide whether any could help you. If you can think of a useful adaptation that is not described in the guide, you can write a brief description in the appropriate section, so that you have a complete record of the adaptations you are considering.

Although this guide is designed to assist you in assessing your own needs, you may wish to ask a family member or friend to help you answer the questions. Sometimes a second pair of eyes will spot something you have overlooked.



Getting the work done

You, a family member, or a friend may possess the knowledge and special skills required to successfully carry out some of the adaptations you have identified.

However, if you are going to get a contractor to carry out the work, it is advisable to obtain more than one estimate. This guide, complete with your checks and descriptions, can be used as the basis for obtaining tenders and negotiating with the contractors.

You may have to be selective in choosing adaptations in order to stay within your budget, so be sure to concentrate on the adaptations that will be of most benefit to you. Every house and every person's requirements are different, so be sure you agree only to adaptations that you need and want.

You may wish to call or visit your local Canada Mortgage and Housing Corporation (CMHC) office. The staff will be pleased to advise you about other sources of information or assistance.

If your home is rented, you should check with your landlord and obtain written confirmation verifying that the proposed adaptations may be made.

Table of contents

			PAGE
SECTION	1	Getting in and out of the home	1
SECTION	2	Using the stairs	4
SECTION	3	Moving around your home	5
SECTION	4	Using the kitchen	7
SECTION	5	Using the bathroom	11
SECTION	6	Getting out of a bed or chair	17
SECTION	7	Using closets and storage areas	18
SECTION	8	Doing laundry	19
SECTION	9	Using the telephone or answering the door	20
SECTION	10	Controlling light and ventilation	23

Getting in and out of the home

1.1 Do you have any difficulty walking from the garage, the backyard or the street to your door?

No ➤ If no, go to next question

Yes If yes, check the adaptations below which would help you



- Repair holes or uneven joints in walking surfaces that could cause tripping
- Widen walkway
- Add steps to remove steep slope
- Add a ramp to bypass existing steps
- Install or repair handrails along walkway, ramp, and steps
- Provide non-slip finish on walking surfaces
- Other (describe)

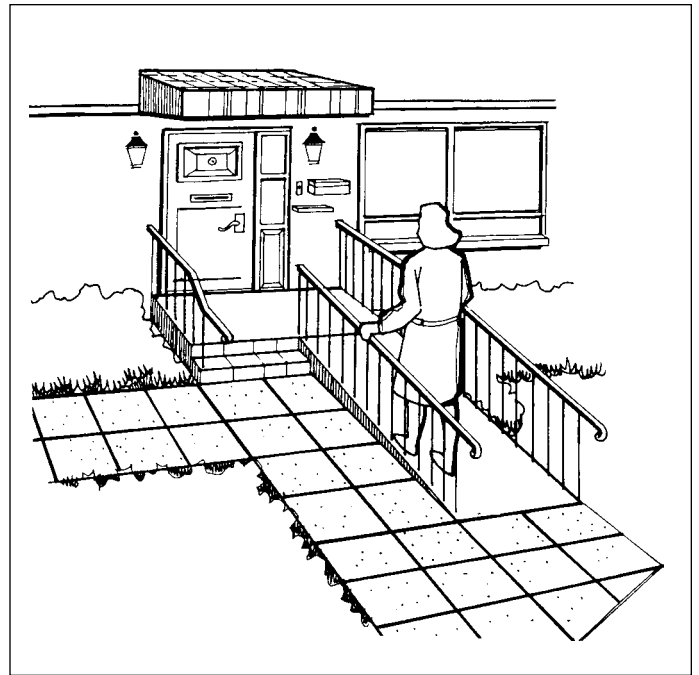

A ramp next to existing steps allows a person using a walker or a wheelchair to bypass the steps. Handrails guide and provide support for persons with poor vision, balance or mobility.

Getting in and out of the home

(continued)

1.2 Do you have any difficulty due to poor lighting along the walkway leading to your home?

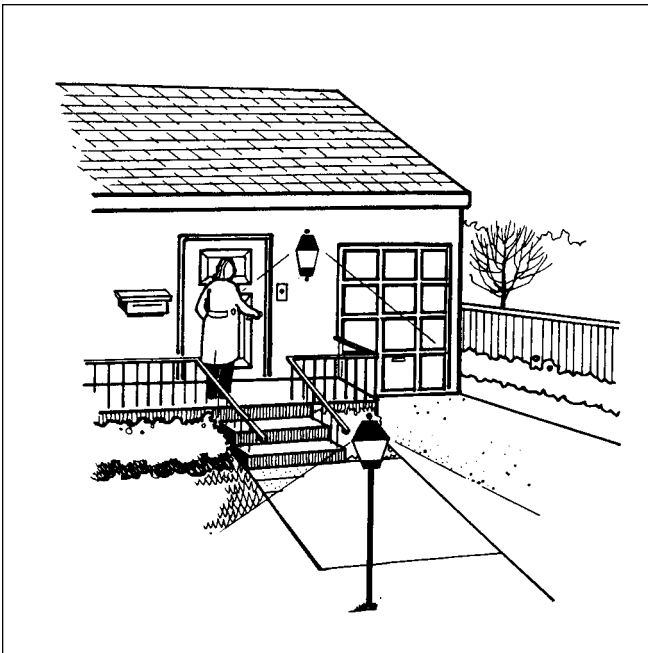

- No ➤ If no, go to next question
- Yes
 ▼
 If yes, check the adaptations below which would help you
- Install light fixtures or flood-lights to illuminate entrances, steps and walkways
 - Install easily accessible light switches or sensors to control outside lights
 - Other (describe)

Well-lighted walkways, steps and entrances, as well as colour contrasts, help people with poor vision to detect obstacles.

Getting in and out of the home

(continued)

1.3 Do you have any difficulty with outside doors?

No ➤ If no, go to next question

Yes If yes, check the adaptations below which would help you



- Remove screen door
- Reduce height of door threshold and adjust or replace door as necessary
- Add a grab bar or handle near step or threshold
- Install a delayed action door closer
- Replace locks to make operation easier or increase security
- Install lever-type door handles
- Install small shelves inside and outside entrances at elbow height to hold parcels while opening doors
- Use colour contrast on door, door frame, handle, or doorbell
- Other (describe)

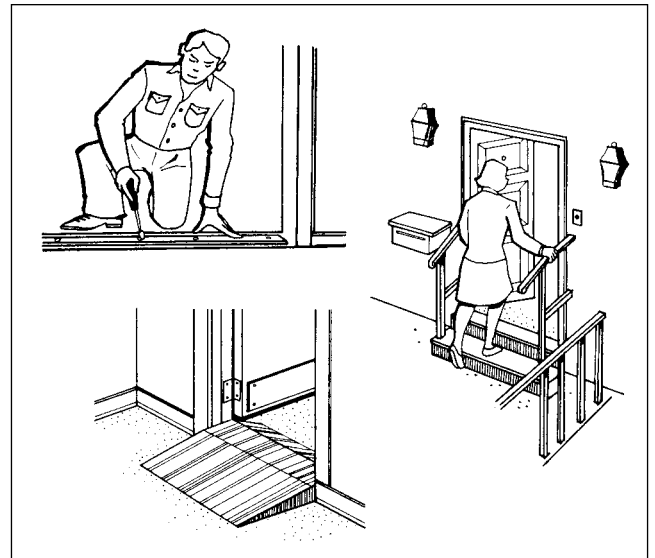

Low thresholds, small ramps or extra steps with a grab bar or handrails can be used at changes in floor levels in door openings.

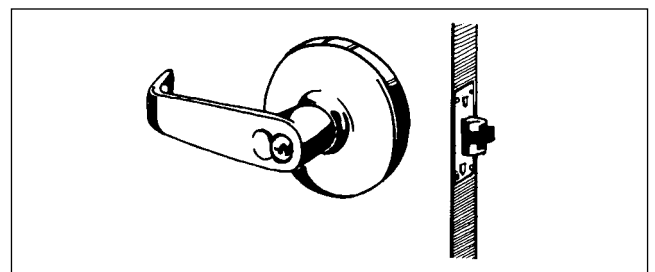

A lever handle is easier to operate for a person with a poor grip. A single-action, dead-bolt lock is secure and requires the use of only one hand.

Using the stairs

2.1 Do you have any difficulty using the stairs inside your home?

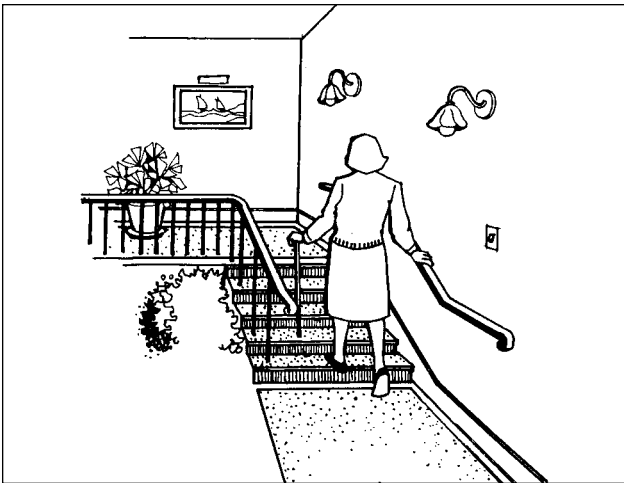

A well-lighted staircase with solid handrails on both sides and extending beyond the top and bottom of the stairs, together with steps visually prominent, is safer and easier for people with poor balance or vision.

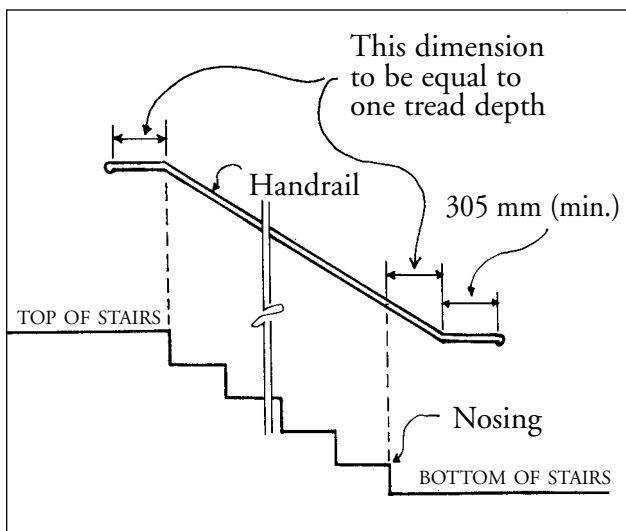

No ➤ If no, go to next question

Yes If yes, check the adaptations below which would help you



- Improve lighting in stairs
- Install two-way light switches at top and bottom of stairs
- Install or repair handrails (on both sides)
- Maintain a consistent handrail height above all nosings and above floor
- At the top of the stairs, extend handrail horizontally, the length of one tread, beginning directly above the last nosing
- At the bottom of the stairs, extend handrail the length of one tread beyond the first nosing. At this point, extend handrail horizontally at least 305 mm
- Replace worn stair coverings
- Mark stair nosings permanently (not with tape) if they are not distinctly visible. Note that a painted stripe can work well, and look good, on carpet
- Relocate bedroom to main floor level
- Relocate laundry room to the main floor level
- Relocate or add a toilet on main floor or bedroom level
- Other (describe)

Moving around your home

3.1 Do you have any difficulty moving from one room to another?

No ➤ If no, go to next question

Yes If yes, check the adaptations below which would help you



- Reduce height of, or eliminate, door thresholds at room entrances
- Use color contrast or changes in floor texture wherever there is a change in floor level
- Install "swing clear hinges" on doors to widen doorways
- Install handrails or grab bars where there are significant changes in floor levels
- Install handrails along corridor walls
- Other (describe)

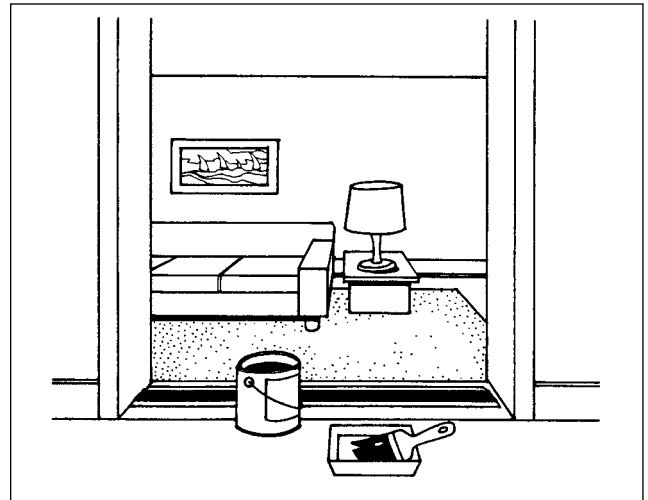

Strong colour contrast strips or changes in floor texture can help people with poor vision detect possible obstacles when moving between rooms.

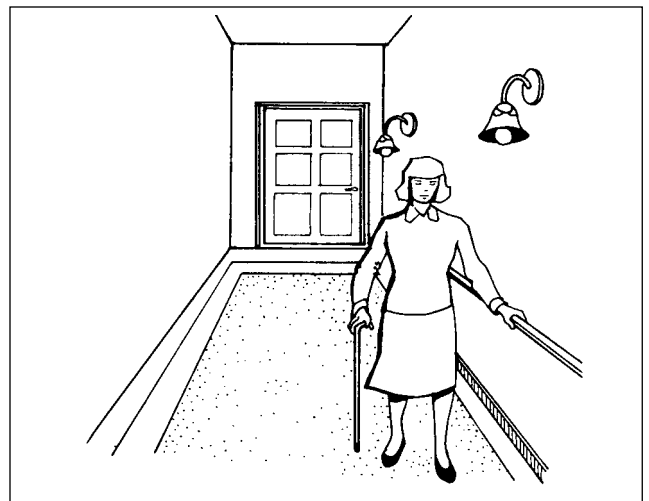

Handrails along corridors help people with poor balance or mobility.

Moving around your home

(continued)

3.2 Do you have any difficulty with doors?

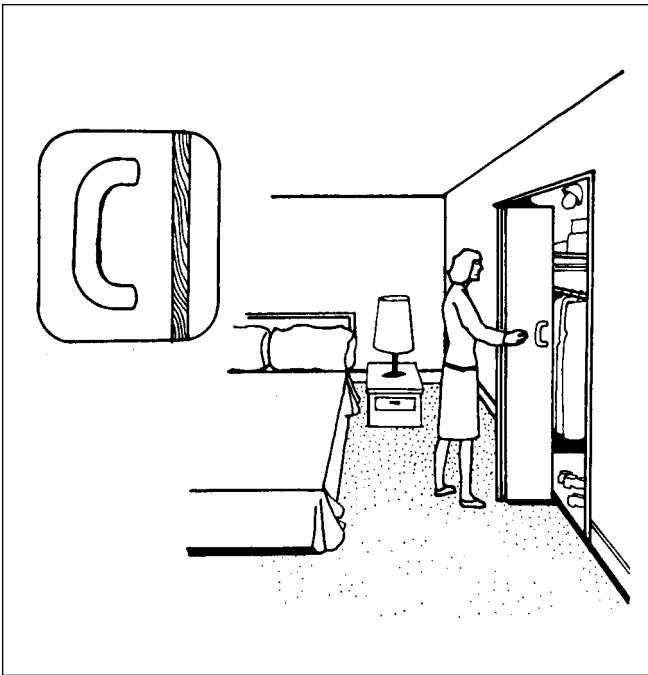

A large "D" shaped handle can be pulled by people with decreased movement and strength in their hands.

- No** ➤ If no, go to next question
- Yes** If yes, check the adaptations below which would help you
 ▼
- Repair door frame or door hinges
 - Reverse direction of door swing
 - Replace door knobs with lever-type door handles
 - Install sliding, bi-folding or accordion doors to closets and pantry
 - Install "D" type handles or loop handles on bi-folding, sliding or accordion doors
 - Other (describe)

Using the kitchen

4.1 Do you have any difficulty working at the sink or using the faucets?

- No** ➤ If no, go to next question
- Yes** If yes, check the adaptations below which would help you
 ▼
- Adjust sink to a convenient height
 - Create a knee-space under the sink to enable you to work from a seated position (insulate any hot-water pipes)
 - Install lever-type faucets or a faucet with a single lever to control flow and temperature
 - Relocate faucets for easier access
 - Other (describe)



If you usually stand while using the sink, the sink should be at a height requiring minimal bending. If you wish to sit while using the sink, there should be knee space, and the sink and faucets should be positioned to require minimal stretching.

Using the kitchen

(continued)

4.2 Do you have any difficulty working at the counter?

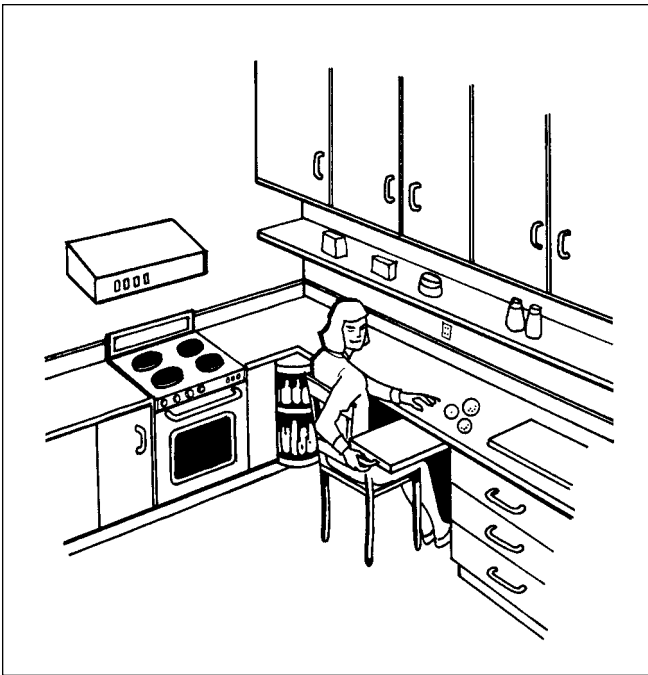

Pull-out shelves enable you to carry out food preparation in a seated position. "U" or "L" shaped counters minimize walking distances between tasks.

- No** ➤ If no, go to next question
- Yes** If yes, check the adaptations below which would help you
 ▼
- Adjust counter height to a convenient working level
 - Install additional counter or storage space
 - Install pull-out shelves under counter to enable you to work from a seated position
 - Remove a cupboard to create knee space under counter for working in a seated position
 - Other (describe)

Using the kitchen

(continued)

4.3 Do you have any difficulty reaching or using cupboards or storage space?

- No** ➤ If no, go to next question
- Yes** ▼ If yes, check the adaptations below which would help you
- Lower existing cupboards
 - Lower shelves in cupboard
 - Install pivoting or revolving shelves in corner cupboards
 - Add cupboards or shelves at convenient heights
 - Add a vertical cupboard or pantry
 - Add pull-out storage units under counter
 - Install "D" type handles on cupboards or drawers
 - Other (describe)

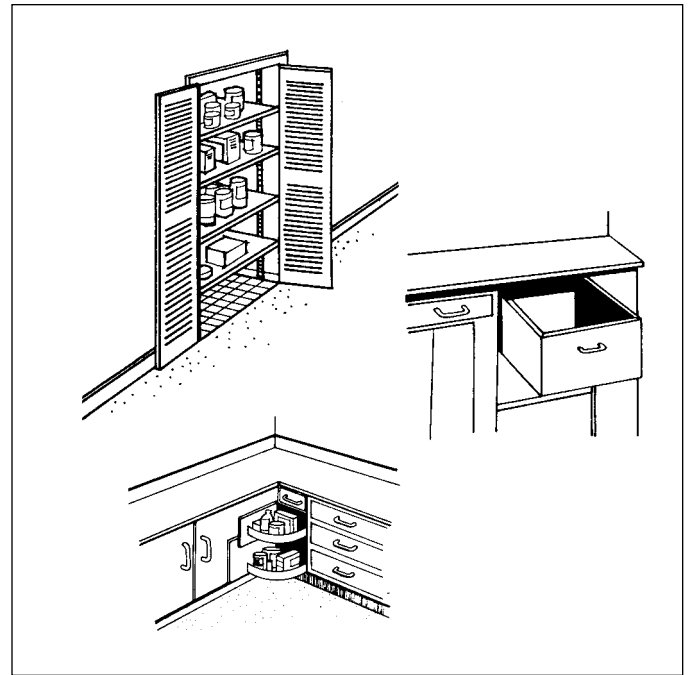

Pivoting or revolving shelves in corners, pull-out storage units and large vertical cabinets make storage more accessible.

Using the kitchen

(continued)

4.4 Do you have any difficulty using appliances?

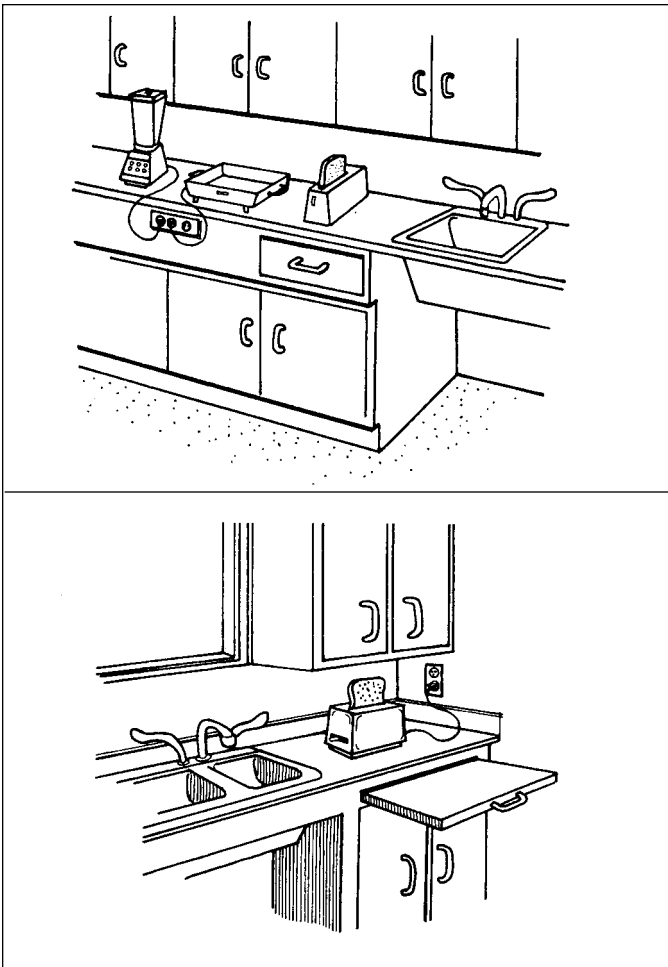

Install electrical outlets so that small kitchen appliances can be used in convenient locations without being moved.

- No ➤ If no, go to next question
- Yes
- ▼
- Install additional shelves or counter top to accommodate small appliances
 - Provide electrical outlets for small appliances in more convenient locations
 - Provide heat-proof, pull-out shelf beside oven
 - Install a heat-proof surface on counter next to range or stove
 - Install smoke and heat detectors outside, but close to, kitchen
 - Install a fire extinguisher near kitchen exit
 - Other (describe)

Using the bathroom

5.1 Do you have any difficulty using the wash basin or the faucets?

- No** ➤ If no, go to next question
- Yes** If yes, check the adaptations below which would help you
 ▼
- Adjust wash basin to a convenient height
 - Create a knee-space under the basin to enable you to use it from a seated position (insulate any hot-water pipes)
 - Strengthen basin with legs or solid cabinet
 - Install faucet with a single lever to control flow and temperature
 - Relocate faucet to front or side for easier access
 - Other (describe)

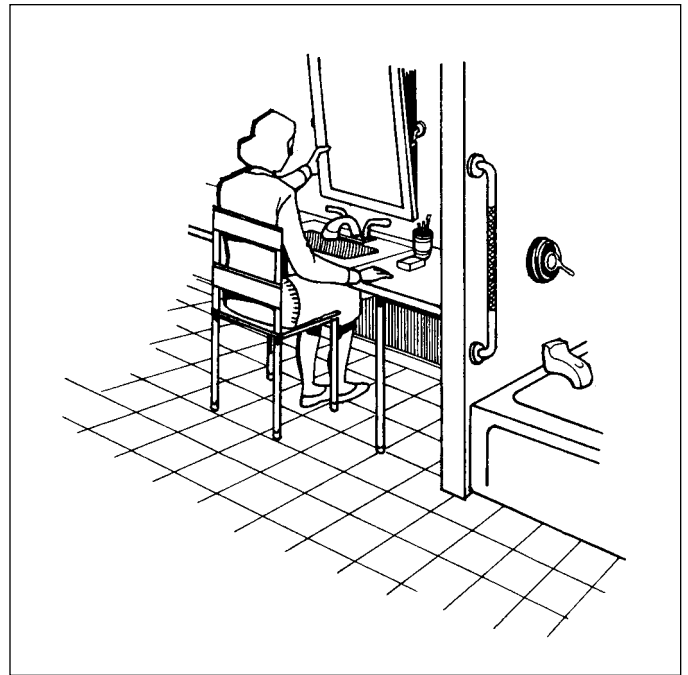

If you tend to lean, pull or push against the basin, it may need to be supported on legs or a solid cabinet. A cabinet can be designed to allow you to use the basin from a seated position.

Using the bathroom

(continued)

5.2 Do you have any difficulty using or storing personal care items near the wash basin?

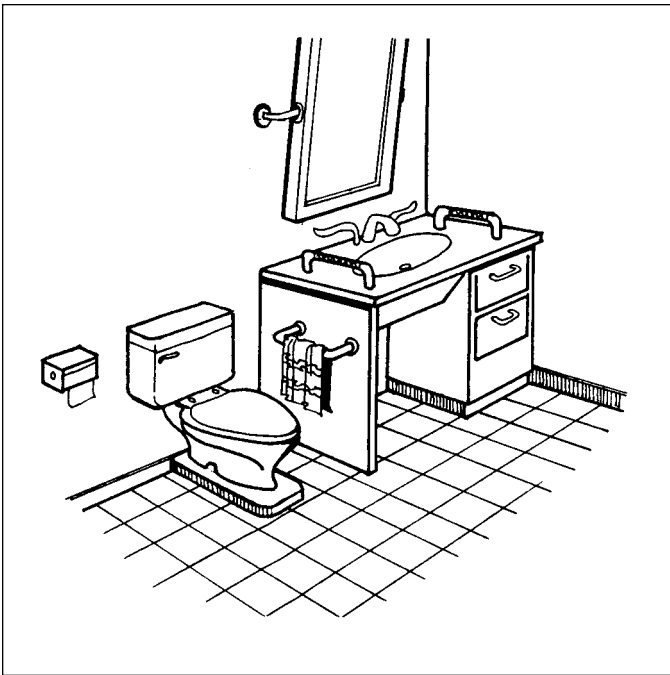

The mirror should be positioned at a convenient height, and tilted if necessary, so that it can be used from a standing or a sitting position.

- No** ➤ If no, go to next question
- Yes** If yes, check the adaptations below which would help you
 ▼
- Install additional counter space around basin
 - Install shelves beside basin for storage
 - Install a grab bar within easy reach
 - Install or reposition a mirror (tilted if necessary) at a convenient height
 - Install additional light fixtures near mirror or medicine cabinet
 - Other (describe)

Using the bathroom

(continued)

5.3 Do you have any difficulty stepping into or out of the bathtub?

- No** ➤ If no, go to next question
- Yes** ▼ If yes, check the adaptations below which would help you
- Install a vertical and an horizontal or angled grab bar by the tub
 - Install non-slip flooring throughout the bathroom
 - Install a non-slip surface in the bathtub
 - Install a commercial or custom-made transfer bench so that the tub can be entered from a seated position
 - Replace bathtub with a shower stall, if difficulty is severe
 - Install a separate shower stall, if difficulty is severe
 - Other (describe)



A vertical grab bar provides support when entering the tub, while an horizontal (or angled) bar helps you to complete the entrance and lower yourself onto a shower seat or to the bottom of the tub.

Using the bathroom

(continued)

5.4 Do you have any difficulty using tub faucets, shower controls or drain plugs?

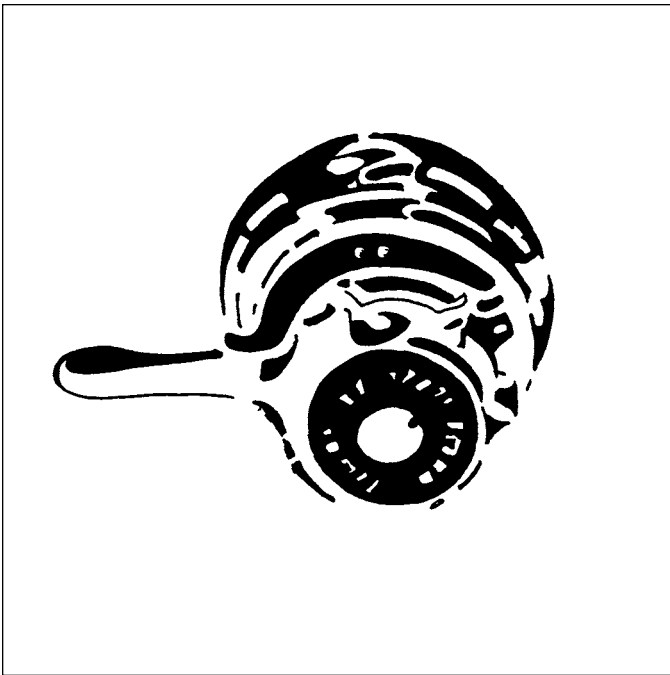

A mixing control with a single lever handle, for shower and bath, can be used by people who have difficulty grasping things.

- No** ➤ If no, go to next question
- Yes** ⚓ If yes, check the adaptations below which would help you
- Install lever-type faucets or a faucet with a single lever to control flow
 - Adjust the hot-water heater or install a device that will prevent the water from reaching too high a temperature
 - Install a drain plug device that can be operated from a convenient height
 - Other (describe)

Using the bathroom

(continued)

5.5 Do you have any difficulty taking a bath or a shower?

- No** ➤ If no, go to next question
- Yes** If yes, check the adaptations below which would help you
 ▼
- Install a hand-held shower on adjustable rod or high-low mounting brackets
 - Install a flip-up seat in tub or shower
 - Install shelves within reach, for personal care items
 - Install a grab bar within reach (see also 5.3)
 - Install a waterproof light fixture over tub or in shower stall
 - Other (describe)

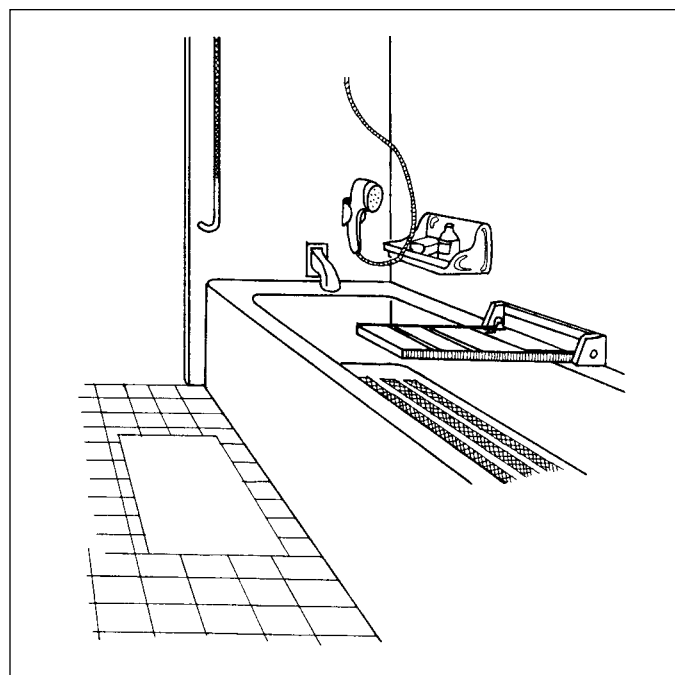

A hand-held shower, mounted on a vertical rod or on a low bracket, makes washing and rinsing easier when you use a seat.

Using the bathroom

(continued)

5.6 Do you have any difficulty using the toilet?

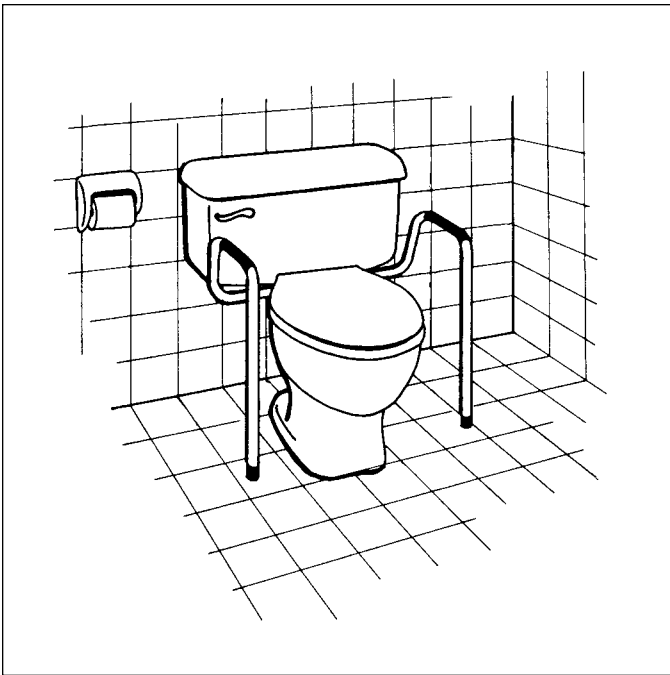

Grab bars can be attached to structural supports in a wall or directly to the toilet.

- No** ➤ If no, go to next question
- Yes**
 ▼ If yes, check the adaptations below which would help you
- Raise toilet seat to a convenient height by using a portable extension or setting the toilet on a pedestal
- Install grab bars
- Adapt flush handle or install activating sensor
- Adapt or relocate toilet paper dispenser
- Other (describe)

Getting out of a bed or chair

6.1 Do you have any difficulty getting into and out of a bed, chair or sofa?

No ➤ If no, go to next question

Yes If yes, check the adaptations below which would help you



- Install grab bars or vertical poles in convenient locations
- Install a trapeze over the bed
- Other (describe)

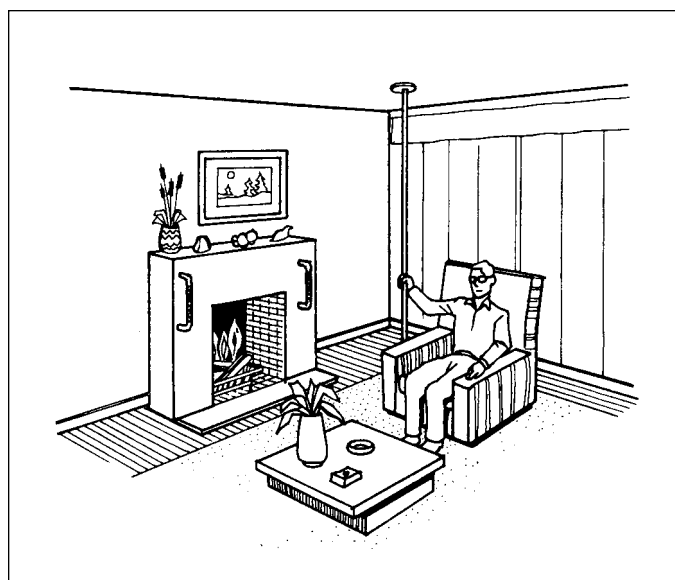
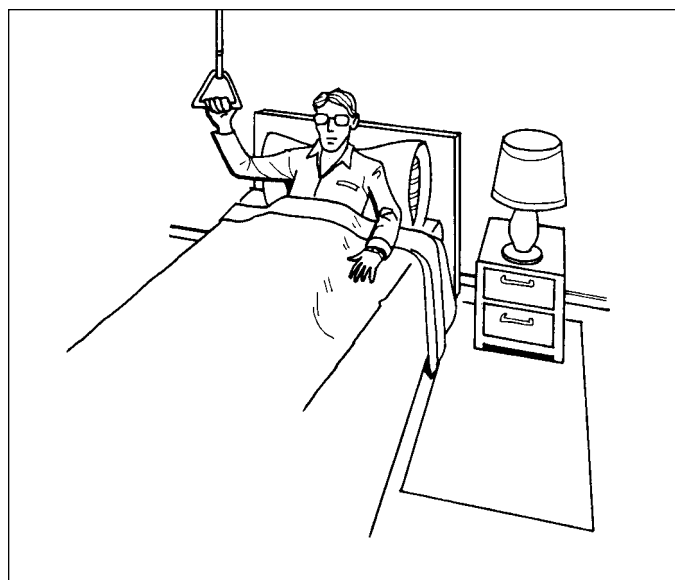

Using closets and storage areas

7.1 Do you have any difficulty reaching clothes, coats, shoes or other items in closets?

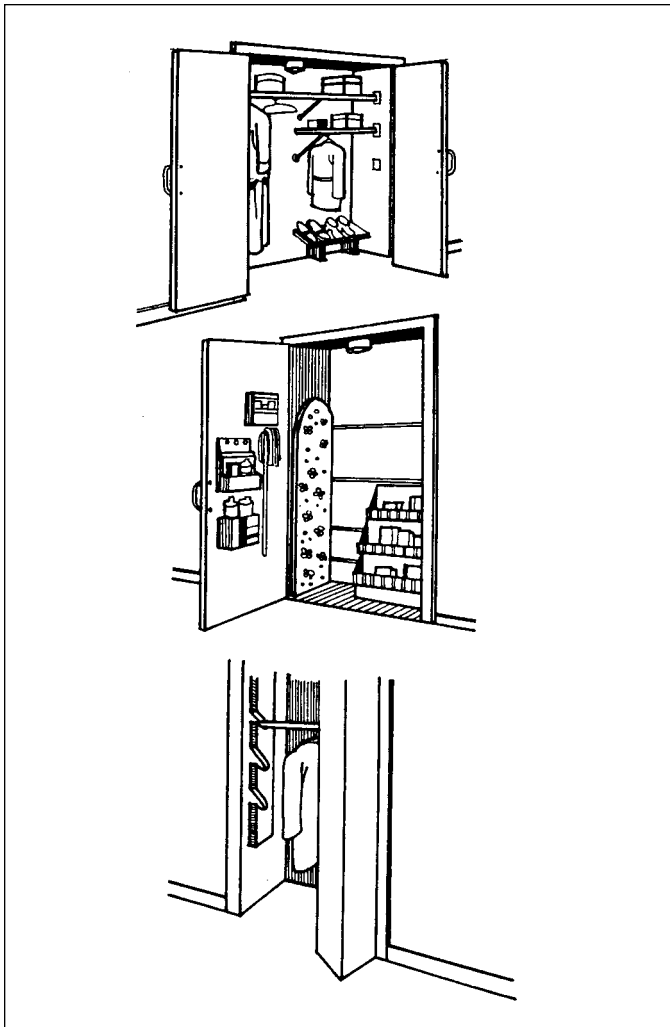

No ➤ If no, go to next question

Yes
 ▼ If yes, check the adaptations below which would help you

- Install bi-folding or accordion doors
- Install lights in closets
- Add or lower rods
- Add or lower shelves
- Add off-floor shelves in closets or at entrances for shoes and boots
- Install hooks or drawers in closets
- Build an easy-to-access storage closet for household tools and appliances (vacuum cleaner, ironing board, brushes, etc.)
- Other (describe)

Reachable shelves and rods in clothes closets and a well-designed utility closet for household tools and appliances help people who cannot reach very high or who have difficulty bending.

Doing laundry

8.1 Do you have any difficulty doing the laundry?

- No** ➤ If no, go to next question
- Yes** If yes, check the adaptations below which would help you
- ▼
- Relocate appliances to a more convenient place
 - Provide shelves or storage near appliances so that washing supplies can be conveniently located
 - Build a counter or large shelf near appliances for sorting and folding clothes
 - Install an electrical outlet and an outside vent for a clothes dryer
 - Adjust clothesline to a convenient height
 - Install a conveniently located clothesline or rack
 - Other (describe)

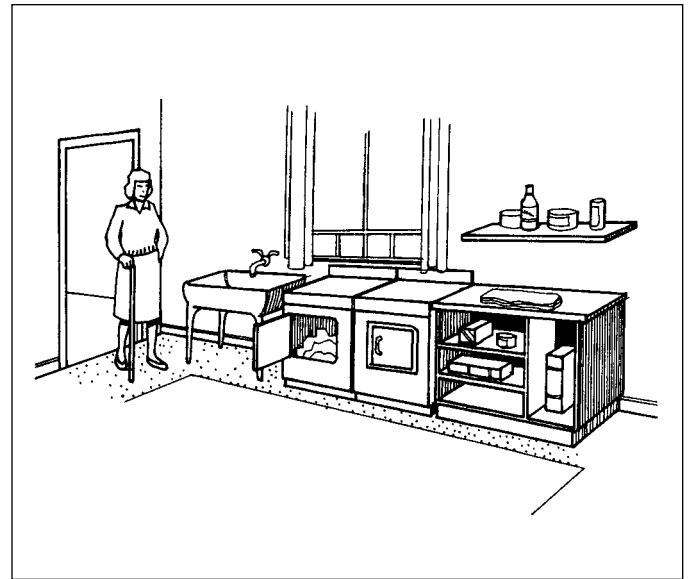

A countertop near the washer and dryer cuts down the number of times you have to move your laundry. A dryer could be useful for people who have difficulty using a clothesline.

Using the telephone or answering the door

9.1 Do you have any difficulty getting to the telephone on time?

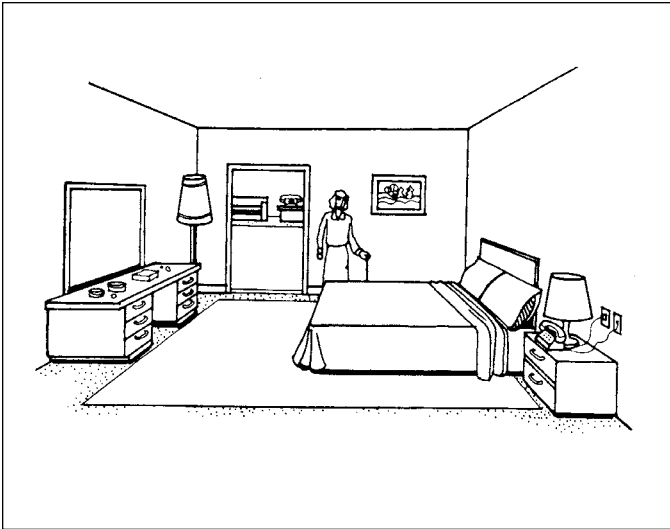

No ➤ If no, go to next question

Yes
 ▼ If yes, check the adaptations below which would help you

Install phone jacks in convenient locations (near bed, sofa) and at a convenient height

Other (describe)

Installing phone jacks in several locations can be helpful to people who cannot move quickly.

Using the telephone or answering the door

(continued)

9.2 Do you have any difficulty identifying visitors or hearing the doorbell?

- No** ➤ If no, go to next question
- Yes** If yes, check the adaptations below which would help you
 ▼
- Install a peephole or view panel at a convenient height
 - Install an easy-to-use intercom in a convenient location
 - Install a flashing light or other sensory cue to indicate when doorbell rings
 - Other (describe)

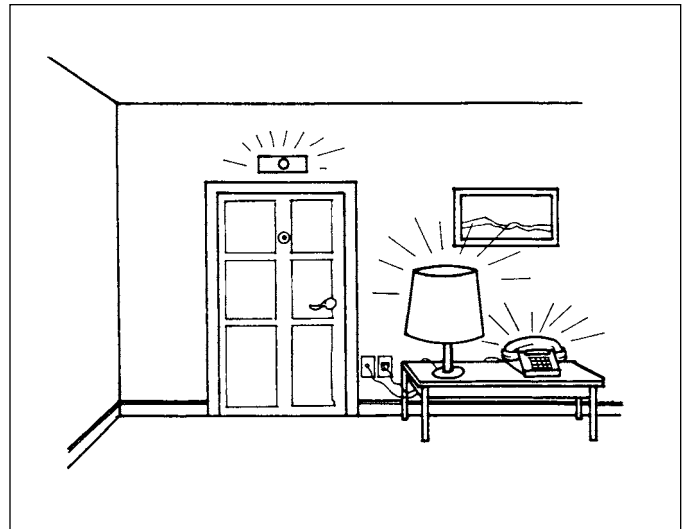

Devices such as a flashing light or sound amplifier to supplement the doorbell may help people with poor hearing or vision.

Using the telephone or answering the door

(continued)

9.3 Do you have any difficulty reaching and emptying the mailbox?

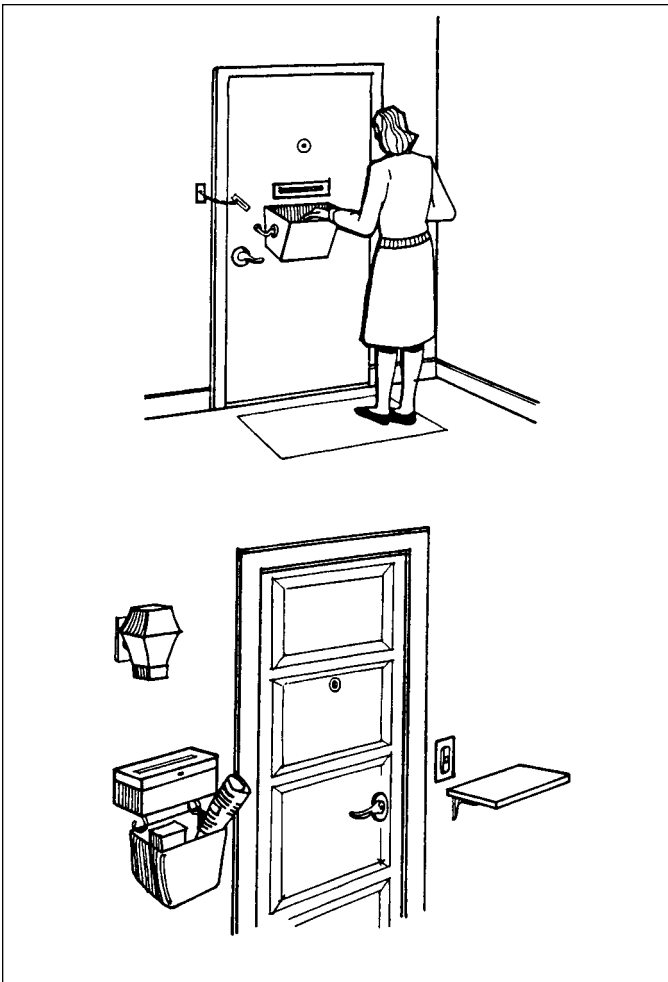

No ➤ If no, go to next question

Yes
 ▼ If yes, check the adaptations below which would help you

Install the mailbox at a convenient height

Install a mail slot with a box or basket on the inside to collect the mail

Install a shelf near the mailbox to hold parcels

Other (describe)

A box or basket under a mail slot, and a hanging bag on the outside for newspapers, will reduce the need to bend down.

Controlling light and ventilation

10.1 Do you have any difficulty due to poor lighting in areas of the home not mentioned previously?

- No** ➤ If no, go to next question
- Yes** If yes, check the adaptations below which would help you
- ▼
- Install light fixtures or electrical outlets for lamps where needed, for example, in hallways, in working areas, in pantry, near reading or activity areas (sofa, bed)
- Install light switches at convenient locations, for example, at room entrances, near bed and sofa, at both ends of corridors, at top and bottom of staircase
- Other (describe)

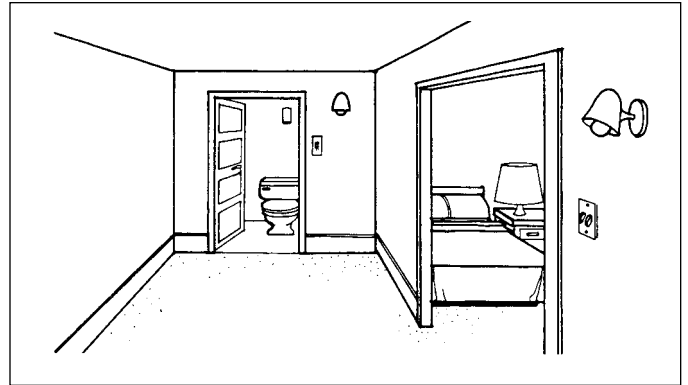

Light switches at doorways and two-way switches in corridors and stairways will minimize the need to move into dark rooms and areas.

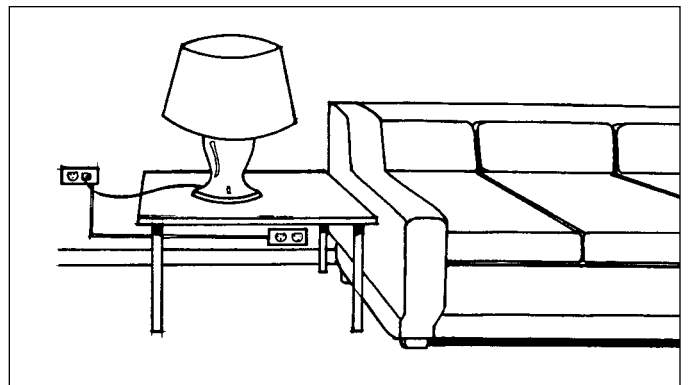

Additional electrical outlets can be conveniently located near reading and activity areas so that table lamps and appliances can be used without the need for long extension cords. The outlets should be positioned at a height that minimizes the need for bending.

Controlling light and ventilation

(continued)

10.2 Do you have any difficulty with windows or sliding patio doors?

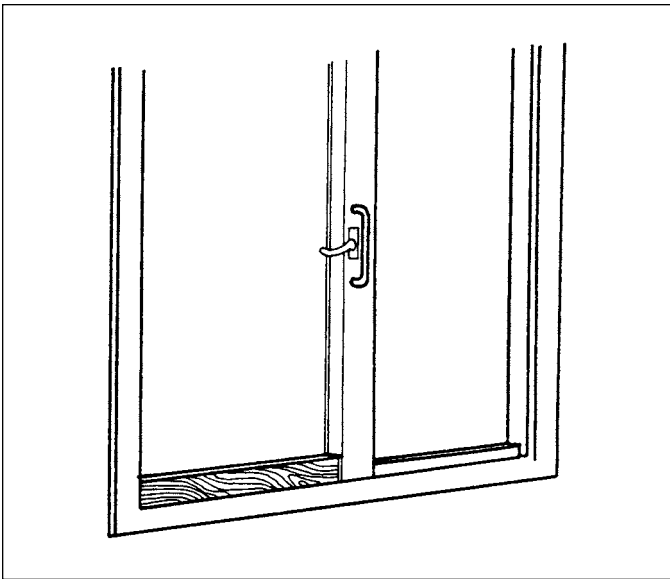

Large "D" type handles and extension arms on locks are easier to grip for people with decreased strength and movement in their hands. A locking bar placed between the frame and edge of a sliding door is effective in preventing forced entry.

 No

 Yes

If yes, check the adaptations below which would help you

- Install easy-to-grasp handles
- Install secure and easy-to-operate locks
- Repair windows and sliding doors so that they open and close easily
- Install security grilles at windows that are vulnerable to forced entry
- Install locking bars on windows or sliding doors that are vulnerable to forced entry
- Other (describe)

OTHER RELATED CMHC PUBLICATIONS

CMHC produces other publications designed to help widen the range of housing choices for Canadian seniors and to assist them in their housing choice decisions. Some examples are:

Maintaining Seniors' Independence Through Home Adaptations: A Videotape

Seniors and professional consultants present a variety of successful home adaptations.

English	61769	\$10.95
French	61798	\$10.95

Maintaining Seniors' Independence: A Guide to Home Adaptations

This innovative assessment tool is designed to be used by a team made up of a senior, an occupational therapist, a design consultant and a building contractor. Together, the team carries out a comprehensive assessment of the seniors' needs.

English	61042	Free
French	61236	Free

At Home with Alzheimer's Disease: Useful Adaptations to the Home Environment

This publication describes a wide range of practical, physical adaptations that can be made to private dwellings to address the needs of people with Alzheimer's disease and their caregivers.

Bilingual Publication	60849	Free
-----------------------	-------	------

How to Lock Out Crime: Protecting Your Home Against Burglary

This publication promotes a proactive approach to safety and security in the home.

English	61124	\$9.95
French	61314	\$9.95

Safe at Home

This publication is designed to help seniors identify the types of personal response services that are, or could be, right for them.

English	61105	Free
French	61295	Free

ASSISTANCE PROGRAMS

CMHC also offers programs* that are designed to improve housing choice and conditions for low-income seniors and Canadians with disabilities.

Home Adaptations for Seniors' Independence (HASI)

This program helps homeowners and landlords pay for minor home adaptations to extend the time that low-income seniors can live in their own homes independently. Low income eligible seniors with age-related disabilities can obtain assistance in the form of a forgivable loan up to \$3,500 for minor adaptations that meet their needs.

Residential Rehabilitation Assistance Program for Persons with Disabilities (RRAP-D)

If your home requires extensive modifications, such as widening doorways and increasing space for wheelchair maneuvering, you may qualify for financial assistance under this program. RRAP-D is intended for low-income homeowners and renters with disabilities.

*In some parts of the country, funding for these or similar programs is provided jointly by the Government of Canada and provincial or territorial government. In these areas, the provincial or territorial housing agency may be responsible for delivery of these programs. Program variations may also exist in these jurisdictions.